

400G-FR4-LPO

Revision 1.0

Specification for 100 Gb/s per Lane Linear Pluggable Optics Single-Mode Optical Fiber Transmission Coarse Wavelength Division Multiplex

Abstract

The 400G-FR4-LPO specification by the LPO (Linear Pluggable Optics) MSA defines a four-wavelength 100 Gb/s/lane, 53.125 GBd, PAM4 optical interface using standard single-mode fiber with reach up to at least 500 m, and host-module electrical interfaces for hosts with DSP based SerDes and RS(544,514) FEC. It builds on the LPO MSA 100G-DR-LPO specification, and IEEE 802.3 and OIF CEI-112G-LINEAR-PAM4 specifications adapted for increased electrical loss channels. It enables Ethernet-like links with 4 lanes for data centers, using low power, high port density, low cost, and low latency pluggable transceiver modules in form factors such as QSFP, QSFP-DD, and OSFP.

Editors

Mark Kimber
Semtech

Oliver Huang
Hisense

Karl Muth
Broadcom

Kumaran Krishnasamy
Broadcom

Eric Bernier
Huawei

THIS VERSION OF THE LPO MSA SPECIFICATION IS PROVIDED "AS IS" AND WITHOUT ANY WARRANTY OF ANY KIND, INCLUDING, WITHOUT LIMITATION, ANY EXPRESS OR IMPLIED WARRANTY OF NON-INFRINGEMENT, MERCHANTABILITY OR FITNESS FOR A PARTICULAR PURPOSE, OR ANY WARRANTY OTHERWISE ARISING OUT OF ANY PROPOSAL, SPECIFICATION OR SAMPLE. THE AUTHORS DISCLAIM ALL LIABILITY, INCLUDING LIABILITY FOR INFRINGEMENT OF ANY PROPRIETARY RIGHTS, RELATING TO THE USE OF INFORMATION IN THIS SPECIFICATION. NO LICENSE, EXPRESS OR IMPLIED, BY ESTOPPEL OR OTHERWISE, TO ANY INTELLECTUAL PROPERTY RIGHTS IS GRANTED HEREIN.

Revision History

Revision	Description	Date revised
1.0	First published revision	2025-09-24

LPO MSA Member Companies

1-VIA	Intel
Accelink	Jabil
Adtran	Juniper Networks
Altera	Keysight
AMD	Linktel
Amphenol	Lumentum
AOI	Lumilens
Arista	LUXIC
Broadcom	Luxshare
ByteDance	MACOM
CIG	MaxLinear
Cisco Systems	MultiLane
Coherent	NewPhotonics
Color Chip	Nokia
Dell	Nubis Communications
Dust Photonics	NTT
Eoptolink	NVIDIA
EXFO	Omniva
Fast Photonics	O-Net
Formerica OptoElectronics	Pioseed
H3C	Ruijie
HG Genuine	Semtech
Hisense	Source Photonics
Huawei	TE Connectivity
Hyper Photonix	TeraHop
InfiniLink Semi	TeraSignal
Infraeo	Texas Instruments
Inpho	VIAVI
InSiGa	Wilder Technologies

Contents

1	Introduction	6
2	Summary of 400G-FR4-LPO Optical Specifications	6
3	Reference Documents	7
4	Functional Description	7
5	System Overview	8
5.1	Link Block Diagram	8
5.2	Linear Optical System Description	8
5.2.1	Detailed Functional Block Diagram of Linear Optical System	8
5.2.2	High Speed Electrical Characteristics	9
5.2.3	Relationship between electrical and optical specifications	9
5.3	Hardware Signaling	9
5.4	Module Management Interface	9
5.5	Module Mechanical Dimensions	9
5.6	Host FEC Requirements	9
5.7	Host Data Path Electrical Insertion Loss	9
5.8	Host Data Path Calibration Information	10
5.9	Host Nonlinear Compensation Function (NLC)	10
5.10	Host Startup Protocol Function (optional)	10
6	Optical Module Functional Specifications	11
6.1	Module Transmit Function	11
6.2	Module Receive Function	11
6.3	Module Global Signal Detect Function	11
6.4	Module Lane-by-Lane Signal Detect Function	11
6.5	Module Global Transmit Disable Function (Optional)	11
6.6	Module Lane-by-Lane Transmit Disable Function	12
6.7	Module Transmit Fault Function	12
6.8	Module Receive Fault Function	12
6.9	Module Equalization Function	12
7	Electrical Specifications	12
8	Optical Specifications	13
8.1	Wavelength Division Multiplexed Lane Assignments	13
8.2	Transmit Optical Specifications at TP2	14

8.3	Receive Optical Specifications at TP3 _____	16
8.4	Illustrative Optical Link Power Budgets _____	18
9	Definition of Optical and Electrical Parameters and Measurement Methods _____	19
10	Additional Measurement Procedures (Informative) _____	20
11	Safety, Installation, Environment and Labeling _____	20
12	Fiber Optic Cabling Model _____	21
12.1	Characteristics of the Fiber Optic Cabling (Channel) _____	21
13	Optimizing Host for TP1a _____	21
14	Test Point Illustration _____	21
15	Glossary _____	22

Figures

Figure 1: Link Block Diagram of a Linear Optical Interconnect..... 8
Figure 2: System Block Diagram..... 8
Figure 3: Measurement Setup for TP2..... 15
Figure 4: Illustration of Receiver Sensitivity Mask..... 17

Tables

Table 1: Summary of 400G-FR4-LPO Optical Specifications 6
Table 2: Signal Detect Conditions 11
Table 3: Operating Ranges and Interface IDs 13
Table 4: CWDM wavelength grid 13
Table 5: Optical Transmit Specifications..... 14
Table 6: Optical Receive Specifications..... 16
Table 7: Illustrative Optical Link Power Budget..... 18
Table 8: Maximum Optical Channel Insertion Loss versus Number of Discrete Reflectances..... 18
Table 9: Optical Fiber and Cable Characteristics 21

1 Introduction

AI clusters in hyperscale data centers are seeking high-speed interconnects, with low power consumption, high port density, low cost, and low latency. Volumes are large enough to demand transceiver solutions that address these specific needs.

The goal of this document is to provide an open specification for 100 Gb/s/lane, 53.125 GBd, PAM4 single-mode fiber links and transceiver interfaces. The 400G-FR4-LPO specification provided in this document is optimized for data-center specific needs and broadly maintains interoperability with standard 100G per lane DSP based LR SerDes. This document provides specifications for a four wavelength per fiber link using the CWDM wavelength grid defined in ITU-T G.694.2 and are spaced at 20 nm. Both the SMF optical signal and the host-module electrical interface are specified. The specification is organized as follows. Sections 1, 2, and 4, and 5 provide an overview. Sections 3, 14, and 15 provide reference material. Sections 6 to 13 provide detailed technical specifications. Section 13 describes a host setup method. Note that sections 7, 9, 10, 11, 12.2 and 12.3, 13 and 14 are referenced to the 100G-DR-LPO specification as the details are unchanged from that specification.

The 400G-FR4-LPO specification is designed specifically to address data center product requirements of:

- Low power consumption
- Low cost
- Low latency
- Compact transceiver form factor: the 400G-FR4-LPO specification is transceiver form-factor agnostic, with QSFP, QSFP-DD, and OSFP as the example form factors
- Compatibility with SMF connectors and cable infrastructure for present and future data centers, as well as telecom client-side interfaces
- Operates with industry standard RS(544,514) forward error correction (FEC)
- Enables a variety of opto-electronic implementation approaches and technologies
- Enable reaches up to at least 500 m based on practical cabling design such as structured cabling or point-to-point cabling

We acknowledge the work done by the IEEE 802.3 and the OIF CEI-112G-LINEAR-PAM4 committees in their efforts in developing underlying standards.

2 Summary of 400G-FR4-LPO Optical Specifications

Table 1: Summary of 400G-FR4-LPO Optical Specifications

Parameter	Value	Units
Fiber type	Single mode	
Nominal wavelengths	1271, 1291, 1311, 1331	nm
Required operating range	0.5 to 500	m
Signaling rate, each lane	53.125	GBd
Modulation format	PAM4	

3 Reference Documents

The following industry standards documents are used to complete this specification:

- [LPO MSA 100G-DR-LPO specification](#)
- [IEEE Std 802.3-2022, Standard for Ethernet](#)
- IEEE Std 802.3ck-2022, Standard for Ethernet for 100 Gb/s electrical signaling
- IEEE Std P802.3dj, Draft Standard for Ethernet Amendment for 1.6 Tb/s
- [OIF CEI-112G-LINEAR-PAM4](#): Common Electrical I/O (CEI)
- [OIF Implementation Agreement](#):
 - Common Management Interface Specification, CMIS
 - CMIS Versatile Control Set, CMIS-VCS
- [QSFP2 Cage, Connector, & Module Specification \(SFF-TA-1027\)](#)
- QSFP-DD/QSFP-DD800/QSFP-DD1600 Hardware Specification
- [QSFP Octal Small Form Factor Pluggable Module](#)
- [ITU-T G.652, Characteristics of a single-mode optical fibre and cable](#)
- ANSI/TIA 568.3-E - Optical Fiber Cabling and Components Standard

4 Functional Description

The LPO optical module performs transmit and receive functions that convey analog signals between the host and the medium. Its electrical interfaces are based on OIF CEI-112G-LINEAR-PAM4 host to module linear interface, while the optical interfaces are similar to, but not identical, to 400GBASE-FR4 and a reach of at least 500 m. (Longer reaches may be achieved and are allowed provided the link budget is met.) The host performs transmit and receive functions including forward error correction, retiming, and digital to analog and analog to digital conversion. The host specifications, which are consistent with 100G-DR-LPO, are based on OIF CEI-112G-LINEAR-PAM4 and adapted for increased electrical channel loss. Note that multiple 400G-FR4-LPO transmit and receive functions may be included in a single module.

5 System Overview

5.1 Link Block Diagram

Figure 1 shows a block diagram of the linear system. There are normative test points to ensure interoperability between host, module and optical fiber.

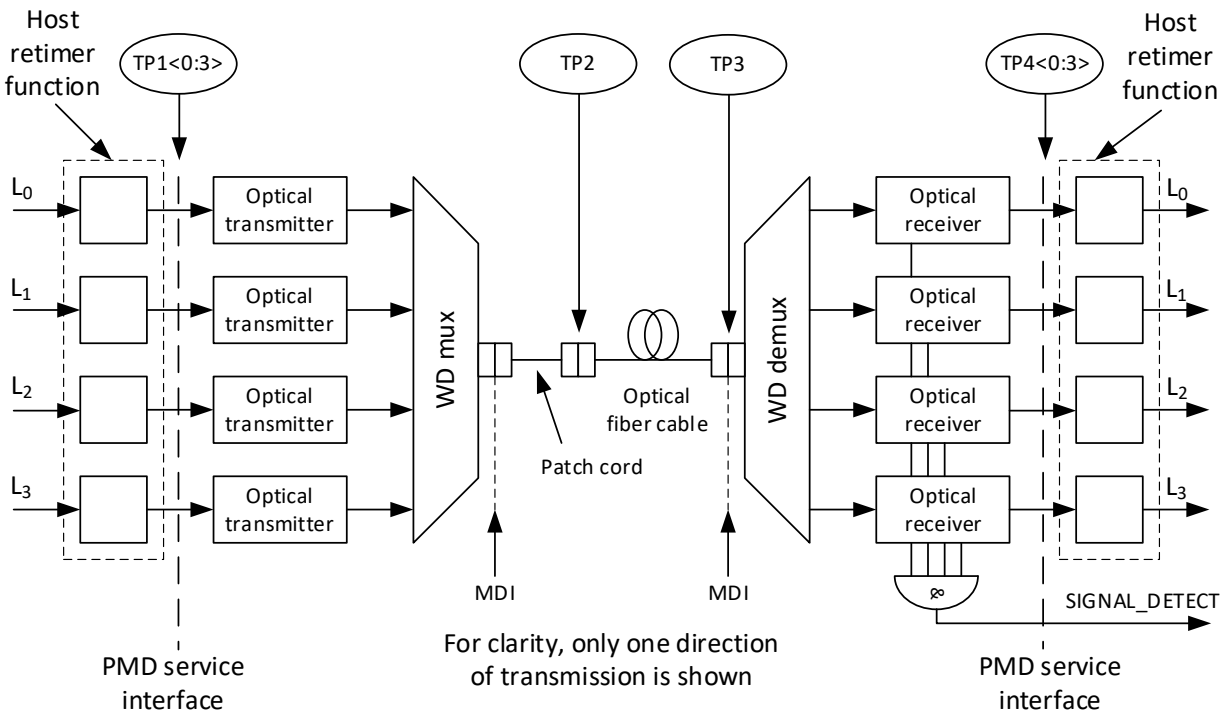

Figure 1: Link Block Diagram of a Linear Optical Interconnect

5.2 Linear Optical System Description

5.2.1 Detailed Functional Block Diagram of Linear Optical System

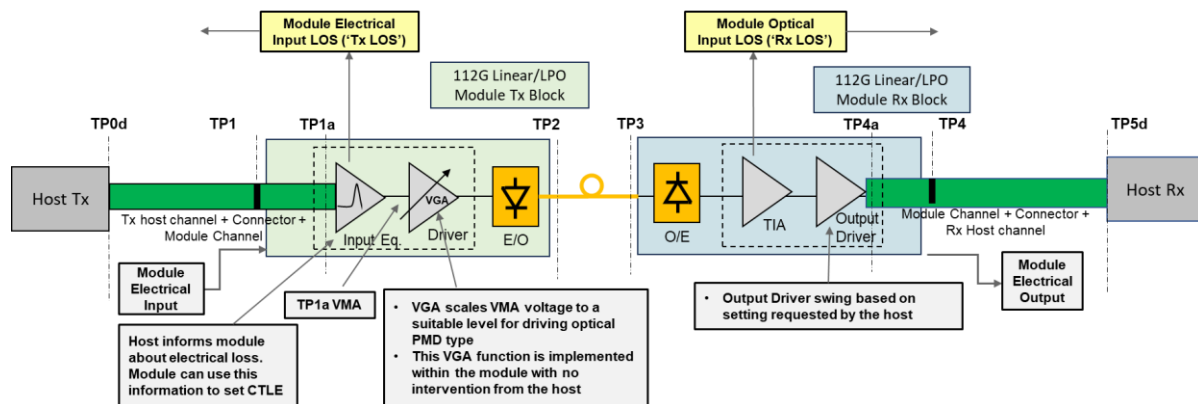

Figure 2: System Block Diagram

5.2.2 High Speed Electrical Characteristics

The data path is linear in both the transmit and receive directions. The electrical specifications, which are consistent with 100G-DR-LPO, are based on OIF CEI-112G-LINEAR-PAM4 and are adapted for increased electrical channel loss. The deviations of the specification to OIF CEI-112G-LINEAR-PAM4 can be found in section 7 (referenced to 100G-DR-LPO specification section 7).

5.2.3 Relationship between electrical and optical specifications

TP1 and TP4 test points are defined in OIF CEI-112G-LINEAR-PAM4 with exceptions which are defined in this document. The TP2 and TP3 test points are defined in this specification. Figure 16 in the 100G-DR-LPO specification illustrates the use of the test points.

The relevant optical specifications at TP2 (section 8.2) shall be met with any electrical input that is compliant with this specification at TP1a (section 7.3, 100G-DR-LPO specification). If an optical module transmitter is tested individually at TP2, the stressors defined in section 7.4.1 (100G-DR-LPO specification) need to be applied. The module output electrical specifications at TP4 shall be met with any optical input signal that is compliant to this optical specification for stressed input sensitivity (section 9.10, 100G-DR-LPO specification) and input sensitivity (section 9.11, 100G-DR-LPO specification) at TP3. The host error performance shall be met with the stressed host input signal defined in 7.6 (100G-DR-LPO specification section 7.6).

TP0d and TP5d are test points directly at the host or module die transmitter and receiver and are used to describe die-to-die electrical insertion loss including device packages.

5.3 Hardware Signaling

Hardware control and status signals are specified in the respective module form factor MSAs.

5.4 Module Management Interface

The contents of the various ID registers shall comply with the requirements of the module MSA and the respective standards such as CMIS with the extensions for LPO.

5.5 Module Mechanical Dimensions

Mechanical dimensions are defined in module form factor MSA specifications.

5.6 Host FEC Requirements

The LPO system relies on the host implementation of RS(544,514) FEC encode and decode functions as defined in IEEE Std 802.3.

- For 4-lane operation, the host system shall use the 2-way interleaved FEC defined in IEEE Std 802.3-2022 Clause 119.

5.7 Host Data Path Electrical Insertion Loss

In order to ensure that the LPO modules can select the desired equalization gain at a certain host port, the host system writes the test point insertion loss (TP0d to TP1a) at 26.56 GHz (see Figure 2 and Figure 3, 100G-DR-LPO specification) in dB of each port to the LPO module in that port, utilizing the protocol defined in CMIS Versatile Control Set (CMIS-VCS) section 5.18. The module may use this information to set its equalization accordingly, see section 6.9.

5.8 Host Data Path Calibration Information

To ensure that the LPO modules can select the desired equalization gain at a certain host port, the host writes CTLE high frequency gain values gDC and gDC2 in dB of each port to the LPO module injected in this port, utilizing the protocol defined in CMIS Versatile Control Set (CMIS-VCS) section 5.11. The gDC and gDC2 values are the ones that would be used in the reference receiver in Figure 4 of the 100G-DR-LPO specification when passing the host output test at TP1a (section 7.3, 100G-DR-LPO specification). It is recommended that the module uses this information to set its equalization accordingly; see section 6.9 and 7.3.3, 100G-DR-LPO specification.

5.9 Host Nonlinear Compensation Function (NLC)

The host may provide a nonlinear compensation function to linearize the optical transmit eye. The module may request transmitter nonlinear compensation utilizing the protocol defined in CMIS Versatile Control Set (CMIS-VCS) section 5.19.

5.10 Host Startup Protocol Function (optional)

Hosts may optionally use a startup protocol, such as the one defined in IEEE Std 802.3ck-2022 (Clause 162.8.11, formally known as PMD control function, also known as "link training"). Usage of such a startup protocol is permitted if both sides of the link support it and are configured to use it.

Note: Link training for electrical channels, such as the one defined in 802.3ck-2022, will not work with LPO mainly because of AGC circuits in the driver and TIA.

If a startup protocol is used, the initial (default) electrical signal characteristics need to comply with the specifications in sections 7 (100G-DR-LPO specification section 7) and 8. The operation of the startup protocol can cause the electrical signal characteristics to change from those of the initial setting.

The details of configuring both sides to use a startup protocol and the method of optimizing the transmitter signal by the receiver are beyond the scope of this specification.

6 Optical Module Functional Specifications

6.1 Module Transmit Function

The module transmit function shall convert the 4-lane electrical signals into the same number of optical signals. The optical signal streams shall then be delivered to the MDI according to the transmit electrical and optical specifications in this document.

6.2 Module Receive Function

The module receive function shall convert the 4 optical signals received from the optical media into the same number of electrical signals according to the receive electrical and optical specifications in this document.

6.3 Module Global Signal Detect Function

The module shall have a global signal detect function, which is an indicator of the presence of optical signals on all lanes, according to Table 2.

The module global signal detect function is not required to verify whether a compliant optical input signal is being received. No response time requirements on the generation of the signal detect state are imposed.

NOTE - Implementations need to provide adequate margin between the input optical power level at which the signal detect state is set to good, and the inherent noise level of the module including the effects of crosstalk, power supply noise, etc.

Table 2: Signal Detect Conditions

Receive conditions	Signal Detect State
For any lane: Average optical power at TP3 \leq -16 dBm	FAIL
For all lanes: Optical power at TP3 \geq receiver sensitivity (max) in OMA AND compliant optical input signal	Good
All other conditions	Unspecified

Various implementations of the signal detect function are permitted, including implementations that generate the signal detect state in response to the amplitude of the modulation of the optical signal and implementations that respond to the average optical power of the modulated optical signal.

6.4 Module Lane-by-Lane Signal Detect Function

Similarly, the module lane-by-lane signal detect function indicates the presence of an optical signal on a lane.

6.5 Module Global Transmit Disable Function (Optional)

1. This optional function turns off all the optical transmitters so that each transmitter meets the requirements of the average launch power of the OFF transmitter.
2. If a TX_fault is detected, then the module may turn off all the optical transmitters.

The definition of TX_fault is beyond the scope of this specification.

6.6 Module Lane-by-Lane Transmit Disable Function

1. This mandatory lane-by-lane transmit disable function allows the optical transmitters in each lane to be selectively disabled so that the transmitter meets the requirements of the average launch power for an OFF transmitter.
2. If a TX_fault is detected, then the module may turn off the optical transmitter in each lane. The definition of TX_fault is beyond the scope of this specification.

6.7 Module Transmit Fault Function

If the module has detected a local fault on any transmit lane, it shall set TX_fault to logical one. The definition of a local fault on any transmit lane is beyond the scope of this specification.

6.8 Module Receive Fault Function

If the module has detected a local fault on any receive lane, it shall set RX_fault to logical one. The definition of a local fault on any receive lane is beyond the scope of this specification.

6.9 Module Equalization Function

The module needs to provide an equalization function in its transmit path to enable the co-equalization of the host channel from TP0d to TP1a, see Figure 2. The equalization capabilities should match the CTLE characteristics in OIF CEI-112G-LINEAR-PAM4 and in 7.3.3 (100G-DR-LPO specification section 7.3.3).

7 Electrical Specifications

The Electrical Specifications follow the LPO MSA 100G-DR-LPO specification. Please refer to 100G-DR-LPO specification document section 7.

8 Optical Specifications

The required operating range is defined in Table 3. A compliant LPO module operates on single-mode fibers according to the specifications of Table 9. An LPO module which exceeds the operating range requirement while meeting all other optical specifications is considered compliant (e.g., operating at 600 m meets the operating range requirement of 0.5 m to 500 m). The signaling rate for a lane of an LPO module shall be as defined in Table 5. The optical signals at the transmit and receive sides are specified in Table 5 and Table 6. Test points are defined in Figure 1.

Table 3: Operating Ranges and Interface IDs

Media Interface ID	Host Electrical Interface ID	Host Loss	Optical Operating Range
400G-FR4-LPO	LEI-400G-PAM4-4 ¹	0 to 16 dB	0.5 m to 500 m

1 LEI: Linear Electrical Interface

8.1 Wavelength Division Multiplexed Lane Assignments

Table 4: CWDM wavelength grid

Lane	Center Wavelength [nm]	Wavelength range [nm]
L ₀	1271	1264.5 to 1277.5
L ₁	1291	1284.5 to 1297.5
L ₂	1311	1304.5 to 1317.5
L ₃	1331	1324.5 to 1337.5

8.2 Transmit Optical Specifications at TP2

The LPO transmitter shall meet the specifications defined in Table 5 for any electrical input that complies with the specifications in Table 3 in 100G-DR-LPO specification section 7, without re-optimizing host settings. The optical transmit signal is defined at TP2, the output end of a single-mode fiber patch cord between 2 m and 5 m in length. Figure 3 shows the measurement setup.

Table 5: Optical Transmit Specifications

Description	Min.	Max.	Unit
Signaling rate, each lane (range)	53.125		GBd
	- 50 ppm	+ 50 ppm	
Modulation format	PAM4		
Lane wavelength range	1264.5	1277.5	nm
	1284.5	1297.5	nm
	1304.5	1317.5	nm
	1324.5	1337.5	nm
Side-Mode Suppression Ratio (SMSR)	30		dB
Operating link reach	0.5	500	m
Total average launch power		10.4	dBm
Average launch power, each lane	-3.2	4.4	dBm
Optical Modulation Amplitude (OMA _{outer}), each lane ³		3.2	dBm
Launch power in OMA, each lane for max(TECQ,TDECQ) < 1.4 dB ¹	-0.7		dBm
Launch power in OMA, each lane for 1.4 dB ≤ max(TECQ,TDECQ) ≤ 3.4 dB	-2.1 + max(TECQ, TDECQ)		
Difference in launch power between any two lanes (OMA _{outer})		3.9	
Transmitter dispersion and eye closure (TDECQ), each lane ¹		3.4	dB
Transmitter eye closure (TECQ), each lane ¹		3.4	dB
Ceq ² (applies to TECQ and TDECQ)	0.0	2.5	dB
TX overshoot/undershoot		25	%
Average launch power of transmitter OFF, each lane		-16	dBm
Extinction ratio ³	3.0		dB
RIN _x OMA ⁴		-138	dB/Hz
Optical return loss tolerance		17.2	dB
Transmitter reflectance		-26	dB

¹ Even if the TDECQ < 1.4dB, the OMA (min) must exceed the min value. A mask for the launch power is illustrated in Figure 4.

² Ceq is a coefficient defined in IEEE Std 802.3-2022 Clause 121.8.5.3 which accounts for reference equalizer noise enhancement. Negative Ceq is an indication of over-equalization and typically does not lead to optimum link performance and when combined with non-linear distortion can result in impaired link performance.

- 3 Minimum ER needs to increase for OMA > 1.4 dBm to 3.5 dB at 3.2 dBm OMA to keep average launch power at 4.4 dBm or below. High ER above 4.5 dB can result in non-linear distortion and lead to impaired link performance.
- 4 RIN_x OMA with “x” referring to the value for optical return loss tolerance.

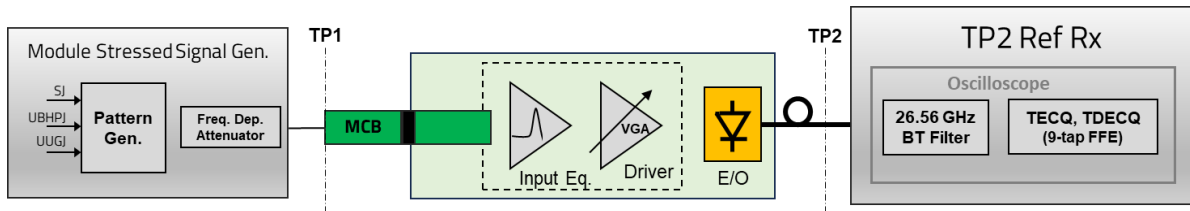

Figure 3: Measurement Setup for TP2

8.3 Receive Optical Specifications at TP3

The module receiver shall meet the specifications defined in Table 6 and section 7.5 (100G-DR-LPO specification section 7). The optical receiver output is measured with an MCB and an oscilloscope. See CEI-112G-LINEAR-PAM4 Figure 29-7. See section 10.2 (100G-DR-LPO specification section 10) for a method of assessing a combination of host and module.

Table 6: Optical Receive Specifications

Description	Min.	Max.	Unit
Signaling rate, each lane (range)	53.125		GBd
	-100 ppm	+100 ppm	
Modulation format	PAM4		
Lane wavelength range	1264.5	1277.5	nm
	1284.5	1297.5	nm
	1304.5	1317.5	nm
	1324.5	1337.5	nm
Damage threshold ¹	5.4		dBm
Average receive power, each lane ²	-6.2	4.4	dBm
Receive power, each lane (OMA_{outer})		3.2	dBm
Difference in receive power between any two lanes (OMA_{outer})		4.1	
Receiver reflectance		-26	dB
Receiver sensitivity (OMA_{outer}) for $TECQ \leq 1.4$ dB, each lane ³		-4.1	dBm
Receiver sensitivity (OMA_{outer}) for 1.4 dB \leq $TECQ \leq 3.4$ dB, each lane ³		-5.5 + TECQ	dBm
Stressed receiver sensitivity (OMA_{outer}), each lane ⁴		-2.1	dBm
Conditions of stressed receiver sensitivity test			
Stressed eye closure for PAM4 (SECQ), lane under test		3.4	dB
OMA_{outer} of each aggressor lane	1.4		dBm

- ¹ The receiver shall be able to tolerate, without damage, continuous exposure to an optical input signal having this average power level.
- ² Average receive power, each lane (min) is informative and not the principal indicator of signal strength. A received power below this value cannot be compliant; however, a value above this does not ensure compliance.
- ³ A mask for the receiver sensitivity is illustrated in Figure 4.
- ⁴ Measured with conformance test signal at TP3. See section 9.10 (100G-DR-LPO specification section 9).

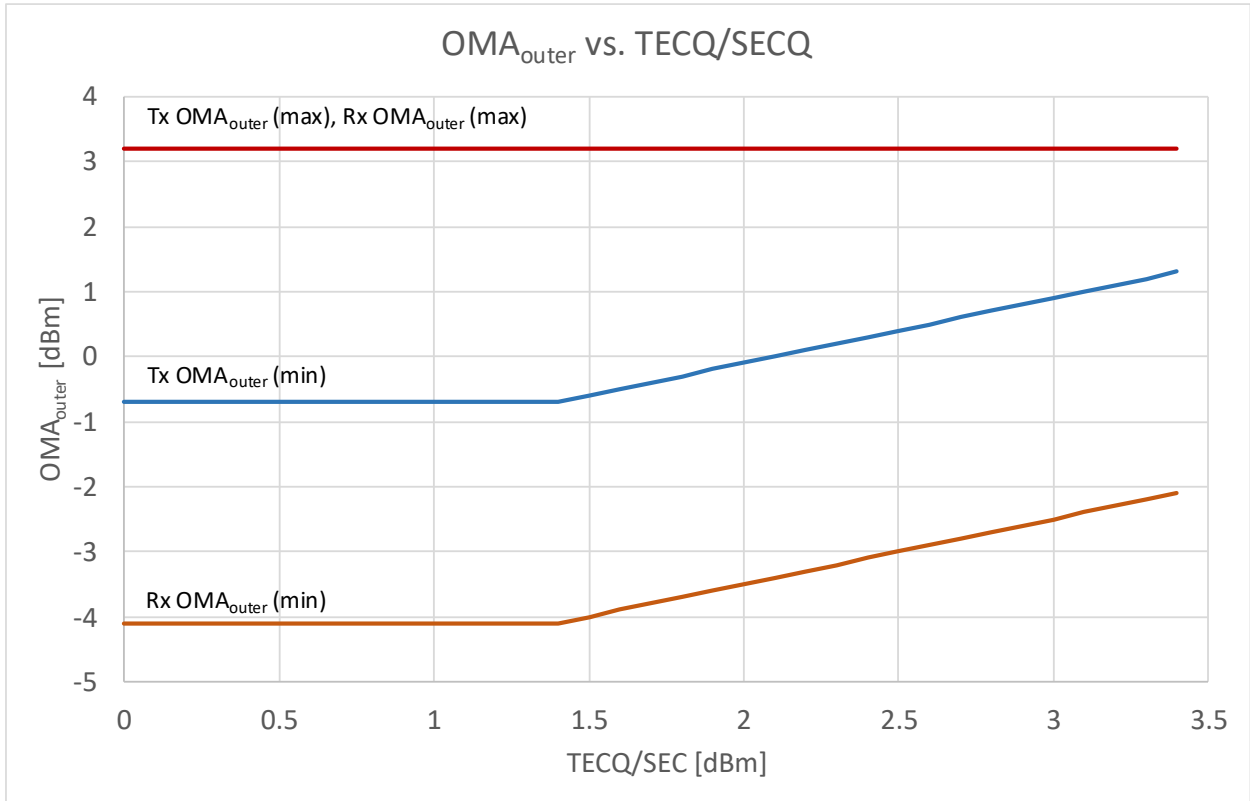

Figure 4: Illustration of Receiver Sensitivity Mask

8.4 Illustrative Optical Link Power Budgets

An illustrative power budget and penalties for optical channels is shown in Table 7. Table 8 shows maximum optical channel insertion loss versus the number of discrete reflectances.

Table 7: Illustrative Optical Link Power Budget

Parameter	Value	Unit
Operating distance max.	0.5	km
Fiber loss	0.25	dB
Connector and splice losses	2.75	dB
Total channel loss ¹	3.0	dB
MPI penalty ¹	0.4	dB
TDECQ (max.)	3.4	dB
Total Power Budget	6.8	dB

¹ Total optical channel loss and MPI penalty as part of the link power budget. See Table 8 for max. channel loss versus discrete reflectances.

Table 8: Maximum Optical Channel Insertion Loss versus Number of Discrete Reflectances

Maximum channel insertion loss (dB)	Number of discrete reflectances > -55 dB and ≤ -45 dB							
		0	1	2	3	4	5	6
Number of discredited reflectances > -45 dB and ≤ -35 dB	0	3	3	3	3	3	3	3
	1	3	3	3	3	3	3	3
	2	3	3	3	3	3	3	3
	3	3	3	2.9	2.9	2.9	2.9	NA ¹
	4	2.9	2.8	2.8	2.8	NA ¹	NA ¹	NA ¹

¹ Total number of connectors too high for practical purposes.

9 Definition of Optical and Electrical Parameters and Measurement Methods

The Definitions of Optical and Electrical Parameters and Measurement Methods follow the LPO MSA 100G-DR-LPO specification. Please refer to 100G-DR-LPO specification document section 9 with the following exceptions:

1. For stressed receiver sensitivity measurement at minimum SRS OMA, OMA = -2.1 dBm and extinction ratio (ER) = 3.0 dB (section 9.10.1.1) and
2. For stressed receiver sensitivity measurement at maximum SRS OMA, OMA = 3.2 dBm and extinction ratio (ER) = 3.5 dB (section 9.10.1.2).
3. Module receiver sensitivity is defined as

$$\text{RxS} = \max(-4.1, \text{TECQ}-5.5) \text{ dBm, Equation 1}$$

10 Additional Measurement Procedures (Informative)

The Additional Measurement Procedures follow the LPO MSA 100G-DR-LPO specification. Please refer to 100G-DR-LPO specification document section 10. Note that the reference for error statistics test with PRBS31Q (section 10.2.1) should now refer to IEEE Std P802.3dj, Draft Standard for Ethernet Amendment for 1.6 Tb/s, Annex 174A.8. This may change in the final published version.

11 Safety, Installation, Environment and Labeling

The Safety, Installation, Environment and Labelling follow the LPO MSA 100G-DR-LPO specification. Please refer to 100G-DR-LPO specification document section 11 with the exception that the interface ID for the module should be 400G-FR4-LPO.

12 Fiber Optic Cabling Model

12.1 Characteristics of the Fiber Optic Cabling (Channel)

The fiber optic cable requirements are satisfied by cables containing IEC 60793–2–50 type B1.1 (dispersion un-shifted single-mode), type B1.3 (low water peak single-mode), or type B6_A (bend insensitive) fibers and the requirements in Table 9 where they differ.

Table 9: Optical Fiber and Cable Characteristics

Description	Value	Unit
Nominal fiber specification wavelength	1310	nm
Cabled optical fiber attenuation (max)	0.5 ¹	dB/km
Zero dispersion wavelength (λ_0)	$1300 \leq \lambda_0 \leq 1324$	nm
Minimum dispersion ²	$0.0115\lambda[1 - (1324/\lambda)^4]$	ps/nm
Maximum dispersion ²	$0.0115\lambda[1 - (1300/\lambda)^4]$	ps/nm
DGD_max ³	2.24	ps

¹ The 0.5 dB/km attenuation is provided for Outside Plant cable as defined in ANSI/TIA 568.3-E. Section 13.3 in the 100G-DR-LPO specification exhibits connector loss for links with various numbers of LC and MPO connectors.

² Over the wavelength range 1264.5 nm to 1337.5 nm.

³ Differential Group Delay (DGD) is the time difference at reception between the fractions of a pulse that were transmitted in the two principal states of polarization of an optical signal. DGD_max is the maximum differential group delay that the system must tolerate.

The remaining sections of Fiber Optic Cabling Model follow the LPO MSA 100G-DR-LPO specification. Please refer to 100G-DR-LPO specification document section 12 for these additional sections.

13 Optimizing Host for TP1a

The Optimizing Host for TP1a follows the LPO MSA 100G-DR-LPO specification. Please refer to 100G-DR-LPO specification document section 13.

14 Test Point Illustration

The Test Point Illustration follows the LPO MSA 100G-DR-LPO specification. Please refer to 100G-DR-LPO specification document section 14.

15 Glossary

BER	Bit Error Ratio
Ceeq	Electrical Noise Amplification Factor for PAM4
Ceq	Noise Amplification Factor for PAM4
CTLE	Continuous Time Linear Equalizer
CWDM	Coarse Wavelength Division Multiplexing
DFE	Decision-Feedback Equalizer
EECQ	Electrical Eye Closure for PAM4
ERL	Effective Return Loss
fbd	Baud Rate
FEC	Forward Error Correction
FFE	Feed-Forward Equalizer
FLR	Frame Loss Ratio
gDC	CTLE High Frequency Gain
gDC2	CTLE Low Frequency Gain
HCB	Host Compliance Board
LPO	Linear Pluggable Optics
MCB	Module Compliance Board
MDI	Medium Dependent Interface
MPI	Multi Path Interference
MSA	Multi Source Agreement
Nbx	Equalizer Length Associated with Reflection Signal
NLC	Nonlinear Compensation
OMA	Optical Modulation Amplitude
PMD	Physical Media Dependent
PRBSQ	Pseudo-Random Bit Sequence for PAM4
RS	Reed-Solomon Error Correction Codes
RxS	Receiver Sensitivity
σ_G	Standard Deviation
SECQ	Stressed Eye Closure for PAM4
SER	Symbol Error Ratio
SMF	Single Mode Fiber
SSPRQ	Short Stress Pattern Random for PAM4
TECQ	Transmitter Eye Closure for PAM4
TDECQ	Transmitter and Dispersion Eye Closure for PAM4
UI	Unit Interval
VMA	Voltage Modulation Amplitude